

LAY-OUT

X35I

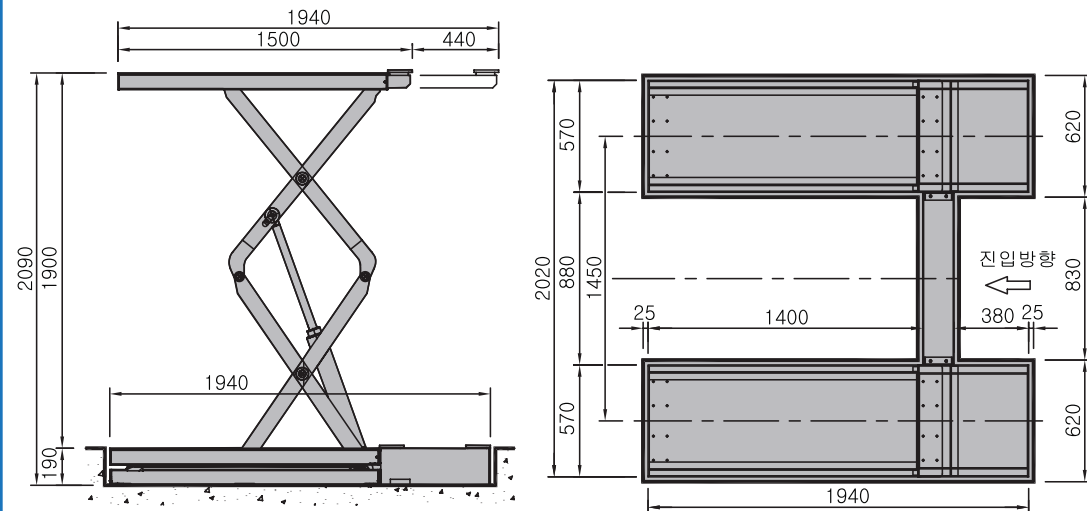

15,000 Cycle Tested

Manufactured in South Korea

SPECIFICATION

Model No.	X35I
Lifting Capacity (kg)	3,500 kg
Min.Lifting Height (mm)	190 mm
Max.Lifting Height (mm)	2,100 mm
Dimension (mm)	1,500(L) X 2,020(W) X 195(H) mm
Power Supply & Motor	2HP X 4P X 220/380V X 50/60Hz
Lifting Time	Approx. 65 sec.
Lowering Time	Approx. 42 sec.
Weight	980 kg

Premium Series
**DOUBLE
SCISSORS
LIFTS**

The Quad hydraulic synchronization system prevents uneven lifting or lowering of the load.

- No cross rails or torsion bars between lifting platforms (for maximum accessibility in the working area).
- Space saving when lift is all raised.
- Completely free floor space when lift is fully lowered.

CAIZER
SCISSOR LIFT



Standard colour blue

Premium
Series

CAIZER SCISSOR LIFT

X35I

SCISSOR LIFT

Premium
Series
CAIZER SCISSOR LIFT
X351

- Second descent for the safety.(option)
- One touch extension ramp.
- Extra low profile version.
- Mechanical locking device.
- Rubber pad.

100% 100% 115% 150% 15000 3,500KG

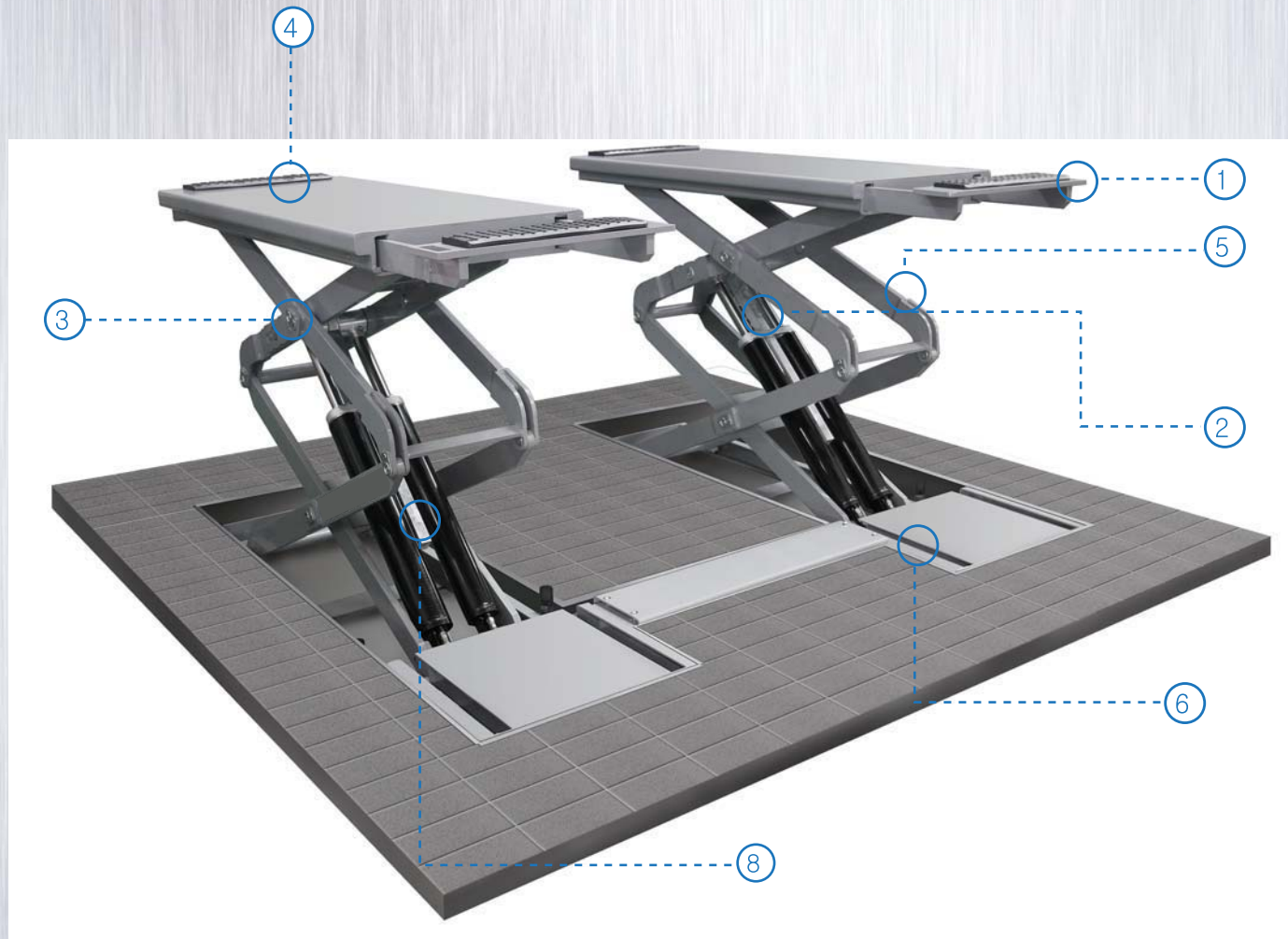

CAIZER LIFT
3,500KG

Inground type

Extremely powerful models for in ground installation. The low space requirement and the lack of mechanical connections between the ramps render them the ideal partner for general service work.

Control Box

The control console features an integrated hydraulic unit and thus considerably helps reduce the installation effort.

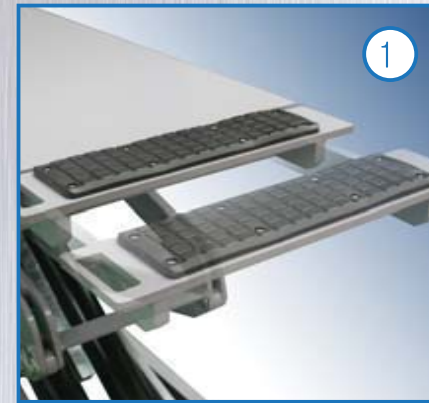

Platform slide extension

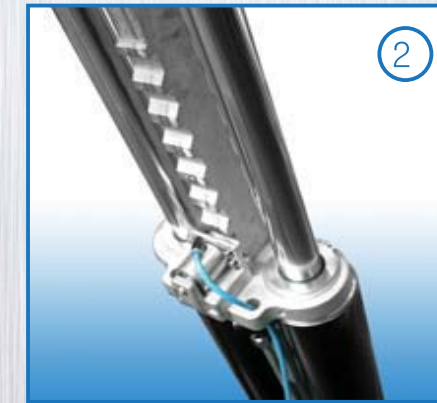

Mechanical locking device

Mechanical locking device with automatic engagement and pneumatic release, ensuring maximum safety when lift is in stand position.



Simple adjustment of balance

Quad self synchronising cylinder for simple adjustment of balance



Rubber pad

Rubber pad provides the convenience to prevent the chassis of the vehicle from being damaged.



Double scissor link structure

Double scissor link structure for wider frame support



Inground version
-In-Ground version provide
unobstructed floor space.
-2.1 metre lift height for comfortable under-body repair



Remote control

Cable remote control for any vantage point operation

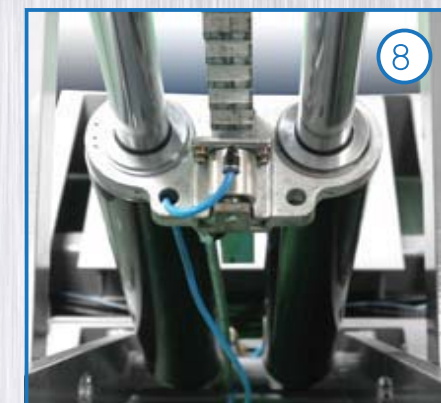

Air cylinder locking system

-Air cylinder locking system to prevent electrical hazard
-Quad self synchronising cylinder for simple adjustment of balance