

megamount 703XLE Racing SUPER-AUTOMATIC

"The most popular tyre changer in its class - once you owned a 703XL nothing else even comes close"

Designed to handle the toughest low profile/alloy rim combinations and run flat tyres without any stress to the operator or the machine.



MAIN FEATURES

- Pneumatic forward/back swinging mounting arm
- Pneumatic up and down movement of the operating arm.
- QuadraClamp - 4 clamping cylinder for ultimate clamping
- Clamping range 10-26 inches
- Inflating pressure limiting device
- Smart blade bead breaker, also for the stiffest tyres.
- Stroke limiter and Auto Return
- Mounting column with 41mm diameter.
- Megafit 2 arm - all functions in one device
- Double speed turntable with pedal switch.

MADE IN  Designed, manufactured and assembled in ITALY



QuadraClamp

This unique and revolutionary turntable design incorporates 4 clamping cylinders. This ensures even, consistent clamping throughout the life of the machine, but more importantly provides a straight 10" to 26" range without any need of adjustment of the clamps.



Auto Return

The 'Auto Return' function automatically pushes the bead breaker blade back out after the bead breaking procedure. This eliminates the problem with the blade getting stuck between the rim and tyre.

Bead Breaker Stroke Limiter

Smart blade can be adjusted to standard or run-flat settings. Pressing the button the arm can be moved to the required starting position. Upon releasing the button the blade will not only remain in that position, but also return to the "home" position after each breaking motion. With our bead breaker stroke limiter, the distance that the blade is required to travel can be adjusted in order to limit the distance to that required in order to break the bead, and prevent any further unnecessary and potentially damaging travel to occur.



Quick Release Interchangeable Head System

To enable fast, tool-free interchange between demount heads. Includes standard, run-flat, raised spoke and plastic heads.

megafit 2 arm

The best possible system for handling run-flat tyres with a single arm.

megamount 703XLE Racing SUPER-AUTOMATIC

Standard Features and Optional Accessories

Standard Features coming with the machine:

- Water separator/oiler with manometer
- Grease pot holder
- Tyre lever
- 10 bar operating pressure limiting device
- CE 3,5 bar inflating pressure limiting device
- Plastic protection package

Optional Accessories



JetBlast

This device helps seat the bead of stubborn sidewalls when inflating. Fully integrated in the machine. Replaces the GT device.

Wheel Lifter

Can be fitted to either 603 or 703 models, and enables the operator to easily raise the wheel up to the turntable by means of a foot-operated pedal device



QX-System

Forget the lever! Pneumatic supported mounting/dismounting tool for fast and safe working. To convert a standard machine into 'lever-less' operation. (tilt arm models only).



Color Options

WDK-KIT
to provide full WDK compatibility.

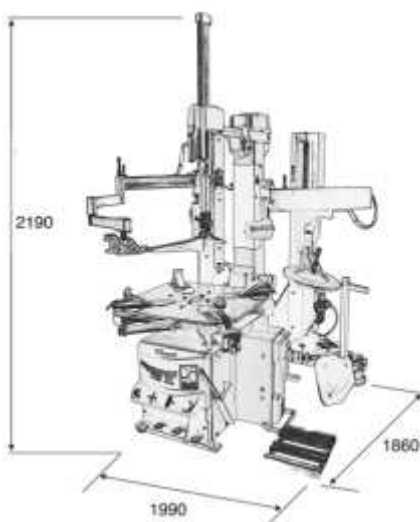

TECHNICAL DATA	
Air pressure	8 to 12bar
Three phase Motor	230-400V /50Hz /550W
Motor single phase (Option)	220V / 50Hz /750W
Self-centring lock external	10"-24"
Self-centering lock internal	12"-26"
Maximal wheel diameter	1100mm
Maximal rim width	16"
Bead breaker pressure	3200kg
Dim.(WxDxH) 703 XLE	113x138x186
Gross weight (packed)	363kg